

# Creep in chipboard

## Part 1 *Fitting 3- and 4-element response curves to creep data*

C. B. PIERCE, J. M. DINWOODIE

*Building Research Establishment, Princes Risborough Laboratory, Princes Risborough, Aylesbury, Bucks, UK*

3- and 4-element spring and dashpot models have frequently been applied to the behaviour of some visco-elastic materials, although somewhat less frequently to wood and wood-based sheet materials which are themselves visco-elastic. However there exists a need to develop a good analytical procedure for fitting the non-linear response curves corresponding to these models to experimental data. This paper describes such a method and applies it to the data from a creep experiment on UF chipboard bending specimens under sustained three-point loading. The computer program written for the solution process illustrates the response curves on a graph plot.

### 1. Introduction

There are many physical and environmental situations where an imbalance may be created in what was previously a steady-state condition. An external stimulus may be applied to a system in equilibrium, and over a period of time the system will adapt itself to its new boundary conditions and settle down into a new equilibrium state.

Many of these time-dependent situations occur in building research. For instance, problems occur in predicting the passage of heat or moisture through external walls of buildings, and in predicting the percentage uptake of preservatives into timber; these are examples of diffusion processes which involve a physical passage of energy, gas or liquid from one region to another. Further examples of these self-equilibrating systems occur in the field of structures, where the work done by loads on an element or structure is distributed throughout the structure as strain energy. The extent to which this redistribution of energy is time-dependent varies with different materials.

Duration of loading is one of the most important factors affecting the strength and deformation of timber and timber products; it is of interest not only to practising engineers, but also to physicists and material scientists who are interested in the problem as one aspect of the behaviour of ma-

terials. With the passage of time the load which a timber member can sustain will decrease progressively, and for a given load the deformation will increase. Thus timber and timber products can be considered neither as truly elastic materials, in which stress is proportional to strain, but independent of rate of strain; nor as truly viscous liquids, where stress is proportional to rate of strain, but independent of strain itself. Rather they possess a combination of these states and like concrete, bitumen and many polymers are referred to as visco-elastic materials.

Fig. 1 illustrates the characteristic deformation-time relationship for a piece of timber under a sustained load where the applied stress is not great enough to initiate early failure, as well as the existence and interaction of the various components comprising the total deformation. On the application of a load at time zero, an instantaneous and completely reversible deformation occurs which represents elastic behaviour. On maintaining the load to time  $t_1$ , the deformation increases, though at an ever-decreasing rate; this increment is known as *creep*. On removal of the load at time  $t_1$  an instantaneous recovery occurs which is approximately equal in magnitude to the initial elastic deformation. With time, the remaining deformation will decrease at an ever-decreasing rate

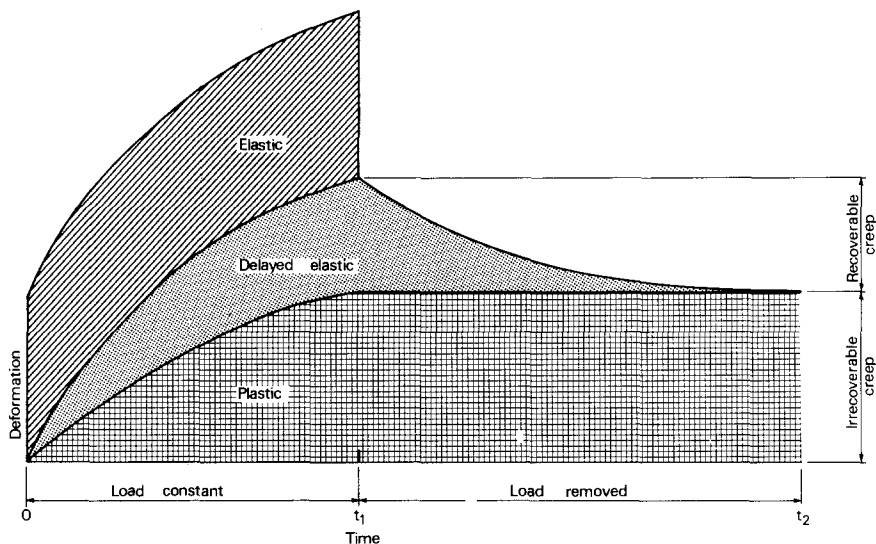

Figure 1 The various elastic and plastic components of the deformation of timber under constant load.

until time  $t_2$  when it becomes constant. The amount of creep that has occurred during loading can be conveniently split into a *recoverable* component, which displays delayed elastic behaviour, and an *irrecoverable* component which is due to plastic or viscous flow.

## 2. Rheological models

Visco-elastic behaviour of this type has been represented by various spring and dashpot analogues in which the spring simulates the elastic component and the dashpot the plastic or viscous component. A number of springs and dashpots are usually combined in the model; two of the more common linear models having three and four elements are illustrated in Fig. 2. The following equations giving the deformation  $Y$  in terms of the time  $t$  and material constants of the components have been derived for these two models (see for example Flugge [1]):

(a) for the 3-element model

$$Y = \frac{\sigma}{E_1} + \frac{\sigma}{E_2} \left[ 1 - \exp\left(\frac{-tE_2}{\eta_2}\right) \right] \quad (1)$$

(b) for the 4-element model

$$Y = \frac{\sigma}{E_1} + \frac{\sigma}{E_2} \left[ 1 - \exp\left(\frac{-tE_2}{\eta_2}\right) \right] + \frac{\sigma t}{\eta_3} \quad (2)$$

The first term on the right hand side represents the elastic deformation and is associated with the

spring constant  $E_1$  (see Fig. 2); the second term, which is time-dependent, represents the delayed elastic or recoverable creep component and is associated with the combined effects of the spring constant  $E_2$  and the dashpot damping coefficient  $\eta_2$ . The third term in Equation 2 represents the flow component or irrecoverable creep and is associated with dashpot constant  $\eta_3$ . As  $t$  tends to infinity the 3-element model tends towards constant deformation, whereas the 4-element model tends towards a constant and positive rate of deformation.

While such analogues have been used quite frequently to represent creep in polymers they have been applied only infrequently in the representation of creep in timber or timber products

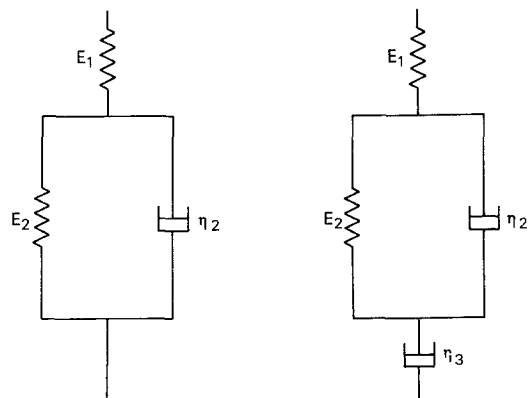

Figure 2 3- and 4- element spring and dashpot analogues.

(Kollman [2], Pentoney [3], Ylinen [4], Szabo and Ifju [5], Senft and Suddarth [6], and Ganowicz and Kwiatowski [7]). Furthermore there have been few instances in any field where the theoretical Equations 1 and 2 have been fitted to experimental data. Of the above research workers, only Szabo and Ifju [5] and Senft and Suddarth [6] have attempted the task. The former workers investigating the creep of small yellow poplar beams adopted the 4-element rheological model to describe creep behaviour; their method of curve-fitting involved a combination of different techniques: all but one of the coefficients were determined by experimental and graphical methods involving a certain degree of subjectivity, with the final coefficient being found by a computer iteration process.

Senft and Suddarth, in investigating the creep of samples of Sitka spruce loaded in compression along the grain, fitted equations for both the 3- and the 4-element models using an iterative solution process based on an existing computer program. Full details of the method of curve fitting are missing from their article, but it would appear that the process involves only the random selection and evaluation of different parameters in order to obtain the best fit; no attempt was made at solving the equations mathematically. Their method may be criticized on the grounds that the calculated coefficients are not meaningful in themselves but only when taken together in the form of Equation 1 or 2. The authors admit that coefficients calculated from different sets of data cannot be compared, since they are dependent upon the initial estimates fed into the program and the sequence of trials the computer goes through to obtain them.

It is the object of this paper to describe an analytical procedure for fitting a creep curve for both the 3- and 4-element models.

### 3. Method of solution

Equation 1 may be rewritten as the statistical model

$$Y = \beta_1 + \beta_2 [1 - \exp(-\beta_3 t)] + \epsilon \quad (3)$$

where  $\beta_1 = \sigma/E_1$ ,  $\beta_2 = \sigma/E_2$  and  $\beta_3 = E_2/\eta_2$  are unknown parameters to be estimated. At a given time  $t$  the observation of the total deformation  $Y$  consists of the value  $\beta_1 + \beta_2 \{1 - \exp(-\beta_3 t)\}$  plus an amount  $\epsilon$ , the increment by which any individual may depart from the fitted curve. Although it is not possible to find  $\beta_1$ ,  $\beta_2$  and  $\beta_3$  exactly without examining all possible occurrences of  $Y$  and  $t$ , the information provided by experiment may be used to find estimates  $b_1$ ,  $b_2$  and  $b_3$  of  $\beta_1$ ,  $\beta_2$  and  $\beta_3$  respectively; then the predicted value of  $Y$  for a given  $t$  is given by

$$\hat{Y} = b_1 + b_2 \{1 - \exp(-b_3 t)\}.$$

Substituting a value of  $t$  into this equation provides a prediction for the amount of deformation at that time.

Similarly, Equation 2 may be rewritten as

$$Y = \beta_1 + \beta_2 \{1 - \exp(-\beta_3 t)\} + \beta_4 t + \epsilon \quad (4)$$

where  $\beta_4 = \sigma/\eta_3$  is the additional unknown parameter.

A non-linear least-squares analysis has been used to estimate the vector of coefficients  $\beta$  in both models (see for example Draper and Smith [8]). Because of the exponential term in the equation for deformation, the solution of the least-squares equations involves an iterative procedure on one parameter ( $\beta_3$ ). Since the 3-element solution may be obtained as a special case of the 4-element solution, only the latter will be derived here.

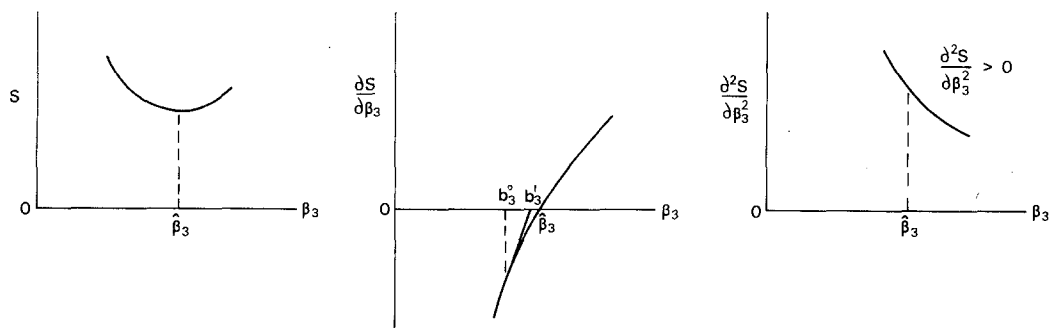

Figure 3 Behaviour of residual sum of squares  $S$  and its derivatives with respect to  $\beta_3$  in the immediate vicinity of  $\hat{\beta}_3$ .

Let

$$S(\beta_1, \beta_2, \beta_3, \beta_4) = \sum_{i=1}^n |Y_i - \beta_1 - \beta_4 t_i - \beta_2 [1 - \exp(-\beta_3 t_i)]|^2 \quad (5)$$

be the residual sum of squares, where  $\beta$  takes any arbitrary valued and  $(Y_i, t_i)$  is an observed data point.

Define  $\hat{\beta}$  to be the values which, when substituted into Equation 5 produce the least possible value of  $S$ .

For  $S$  to be minimised,  $\frac{\partial S}{\partial \beta_1}$ ,  $\frac{\partial S}{\partial \beta_2}$ ,  $\frac{\partial S}{\partial \beta_3}$  and  $\frac{\partial S}{\partial \beta_4}$  must all be zero. Then

$$\frac{\partial S}{\partial \beta_1} = 0 \quad \text{gives} \quad -2 \sum |Y_i - \hat{\beta}_1 - \hat{\beta}_4 t_i - \hat{\beta}_2 \{1 - \exp(-\hat{\beta}_3 t_i)\}| = 0 \quad (6)$$

$$\frac{\partial S}{\partial \beta_4} = 0 \quad \text{gives} \quad -2 t_i \sum |Y_i - \hat{\beta}_1 - \hat{\beta}_4 t_i - \hat{\beta}_2 \{1 - \exp(-\hat{\beta}_3 t_i)\}| = 0 \quad (7)$$

$$\frac{\partial S}{\partial \beta_3} = 0 \quad \text{gives} \quad -2(1 - \exp\{-\hat{\beta}_3 t_i\}) \sum |Y_i - \hat{\beta}_1 - \hat{\beta}_4 t_i - \hat{\beta}_2 (1 - \exp\{-\hat{\beta}_3 t_i\})| = 0 \quad (8)$$

Also

$$\frac{\partial S}{\partial \beta_3} = -2 \beta_2 t_i \exp\{-\beta_3 t_i\} \sum |Y_i - \beta_1 - \beta_4 t_i - \beta_2 (1 - \exp\{-\beta_3 t_i\})| \quad (9)$$

Writing  $Z_i = \exp(-\beta_3 t_i)$  to simplify, we obtain Equations 10, 11, 12 and 13 below

$$\sum Y_i - n(\hat{\beta}_1 + \hat{\beta}_2) - \hat{\beta}_4 \sum t_i + \hat{\beta}_2 \sum Z_i = 0 \quad (10)$$

$$\sum Y_i t_i - (\hat{\beta}_1 + \hat{\beta}_2) \sum t_i - \hat{\beta}_4 \sum t_i^2 + \hat{\beta}_2 \sum t_i Z_i = 0 \quad (11)$$

$$\sum Y_i - \sum Y_i Z_i - \hat{\beta}_1 (n - \sum Z_i) - \hat{\beta}_4 (\sum t_i - \sum t_i Z_i) - \hat{\beta}_2 (n - 2 \sum Z_i + \sum Z_i^2) = 0 \quad (12)$$

$$\frac{\partial S}{\partial \beta_3} = -2 \beta_2 |\sum Y_i t_i Z_i - (\beta_1 + \beta_2) \sum t_i Z_i - \beta_4 \sum t_i^2 Z_i + \beta_2 \sum t_i Z_i^2| \quad (13)$$

Equations 10, 11, and 12 may be put into matrix form for solution of the least-squares equation in the usual way:

$$\begin{bmatrix} \sum Y_i \\ \sum Y_i t_i \\ \sum Y_i - \sum Y_i Z_i \end{bmatrix} = \begin{bmatrix} n & \sum t_i & (n - \sum Z_i) \\ \sum t_i & \sum t_i^2 & (\sum t_i - \sum t_i Z_i) \\ (n - \sum Z_i) & (\sum t_i - \sum t_i Z_i) & (n - 2 \sum Z_i + \sum Z_i^2) \end{bmatrix} \begin{bmatrix} \hat{\beta}_1 \\ \hat{\beta}_4 \\ \hat{\beta}_2 \end{bmatrix} \quad (14)$$

Unfortunately Equation 13 cannot be included in this matrix representation since it is non-linear in  $\beta$ . Also, it may be seen that even the three equations which have been written in matrix form are dependent upon the value of  $\beta_3$ , since  $Z_i = \exp(-\beta_3 t_i)$ .

However, given an initial estimate  $b_3$  for  $\hat{\beta}_3$  Equations 14 can be solved to give estimates for  $\beta_1, \beta_2$  and  $\beta_4$  for that value of  $b_3$ ; this ensures that  $\frac{\partial S}{\partial \beta_1}, \frac{\partial S}{\partial \beta_2}$  and  $\frac{\partial S}{\partial \beta_4}$  are all zero within computational

limits. On the other hand  $\frac{\partial S}{\partial \beta_3}$  calculated from Equation 13 is unlikely to be zero at this stage. An iteration procedure must be found which brings  $\frac{\partial S}{\partial \beta_3}$  closer to zero and hence brings  $b$  closer to the required least squares estimates  $\hat{\beta}$ .

If  $\frac{\partial S}{\partial \beta_3}$  is zero and the value of the second derivative  $\frac{\partial^2 S}{\partial \beta_3^2}$  is positive, a local minimum of  $S$  exists

with respect to  $\beta_3$  (see Fig. 3.) Newton's method of approximation to a root presents a useful algorithm for the solution of  $\frac{\partial S}{\partial \beta_3} = 0$ . By guessing an initial value  $b_3^0$  a better approximation is given by

$$b_3^1 = b_3^0 - \left( \frac{\partial S}{\partial \beta_3} / \frac{\partial^2 S}{\partial \beta_3^2} \right) \quad (15)$$

where both derivatives are evaluated at the point  $\beta_3 = b_3^0$ , and

$$\frac{\partial^2 S}{\partial \beta_3^2} = 2\beta_2 [\Sigma Y_i t_i^2 Z_i - (\beta_1 + \beta_2) \Sigma t_i^2 Z_i - \beta_4 \Sigma t_i^3 Z_i + 2\beta_2 \Sigma t_i^2 Z_i^2].$$

(A geometrical interpretation of Equation 15 may be found in Fig. 3.) This correction may be applied successively to improve the value of  $b_3$  until it is arbitrarily close to  $\hat{\beta}_3$ . After each stage of this iteration procedure, Equations 14 are

solved to obtain new values for  $b_1$ ,  $b_2$  and  $b_4$ .

When  $b_3$  is very close to  $\hat{\beta}_3$ ,  $\frac{\partial S}{\partial \beta_1}$ ,  $\frac{\partial S}{\partial \beta_2}$  and  $\frac{\partial S}{\partial \beta_4}$  are all zero within computational limits with  $\frac{\partial S}{\partial \beta_3}$  arbitrarily small, and the estimates of  $\beta$  are very close to  $\hat{\beta}$ .

#### 4. Application of method to typical creep problem

Table I shows the time-deflection data from an experiment where a sample of ureaformaldehyde chipboard was loaded under three-point bending at constant temperature (20°C) and relative humidity (65%), such that the applied stress was equivalent to 60% of the short-term value; failure of the specimen occurred on the 46th day of continuous loading. The final deformation was twice the initial, i.e. the amount of creep was similar to the initial elastic deformation.

TABLE I Time-deflection data from a chipboard bending specimen

Time (min)	Deflection (mm)	Time (min)	Deflection (mm)	Time (min)	Deflection (mm)
2	3.85	357	4.53	24480	6.37
3	3.88	417	4.56	28800	6.54
5	3.93	477	4.59	30240	6.58
7	3.96	1407	4.94	31680	6.62
9	3.99	1657	4.99	33120	6.66
11	4.01	1917	5.04	34560	6.70
13	4.03	2880	5.20	38880	6.79
15	4.04	3120	5.22	40320	6.79
17	4.05	3360	5.26	41760	6.89
22	4.08	4320	5.36	43200	6.93
27	4.11	4560	5.38	44640	6.96
32	4.13	4800	5.41	48960	7.09
37	4.15	8640	5.70	50400	7.12
42	4.17	9120	5.73	51840	7.16
47	4.18	10080	5.78	53280	7.19
57	4.21	10560	5.81	54720	7.23
87	4.26	11520	5.85	56160	7.38
117	4.32	12960	5.92	57600	7.44
147	4.35	16200	6.09	59040	7.51
177	4.38	20160	6.22	60480	7.56
227	4.43	21600	6.27	61920	7.65
297	4.48	23040	6.32	66240	Failed

TABLE II Application of 3- and 4-element models to above data

Model	Estimated parameters				Minimum residual SS	Multiple correlation $R^2$
	$\hat{\beta}_1$	$\hat{\beta}_2$	$\hat{\beta}_3$	$\hat{\beta}_4$		
3-element	4.27	2.95	0.0000666	0	3.904	0.960
4-element	4.09	1.34	0.000613	0.0000349	0.588	0.994

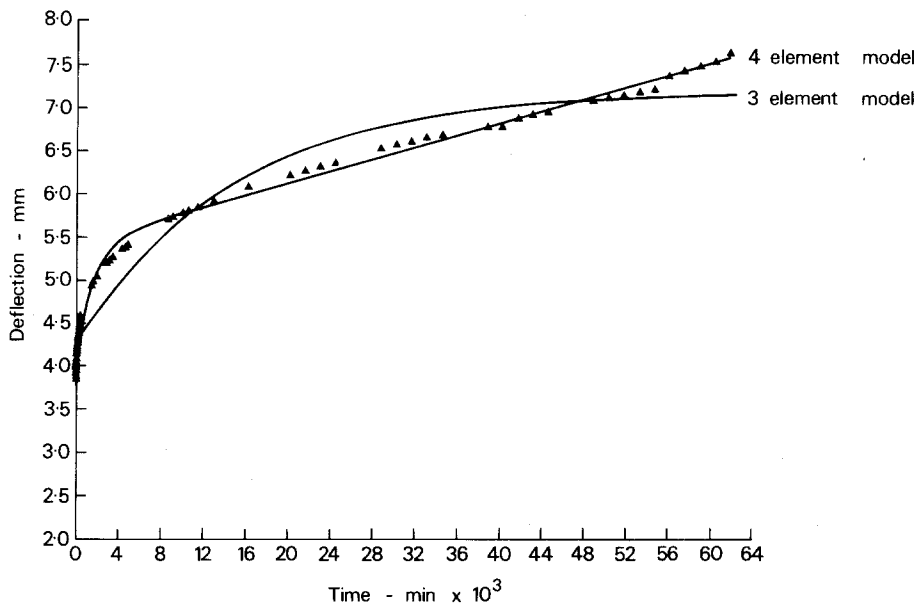

Figure 4 3- and 4-element response curves fitted to creep data in Table I.

A computer program has been written to calculate the least-squares estimates of the parameters of the 3- and 4-element models and also to produce a plot of the two creep curves superimposed on the original data. When applied to the data of Table I the estimated parameters  $\hat{\beta}$  are those shown in Table II, and the graphical representation is shown in Fig. 4. It may be seen that in this case the 4-element model fits the data much more closely than the simpler 3-element model and can account for 99% of the variation in the experimental data. Although both multiple correlations are high at 0.960 and 0.994, the departures from a perfect fit ( $R^2 = 1$ ) are 0.040 and 0.006 respectively which support the impression given by Fig. 4.

The value of rheological models of this type lies in the possibility of predicting long-term performance from short-term investigation: the validity of such a procedure is currently being assessed as part of an extensive investigation of creep in chipboard, and the results will be presented in a later paper in this series. The values of the various coefficients will provide a quantitative comparison of the behaviour of different types of boards or a single type under varying conditions. It is likely that the values of  $\beta$  will also be affected by the level of applied stress and the span to depth ratio of the test specimens.

## 5. Conclusion

A method has been developed for fitting non-linear response curves corresponding to the 3- and 1960

4-element spring and dashpot models to the behaviour of a linear visco-elastic material which creeps under sustained loading. A least-squares approach has been used and because of the exponential term in the governing equations 3 and 4 for the two models the solution process is iterative. A computer program has been written to calculate the least squares estimates of the parameters  $\beta$ , and it also illustrates the response curves on a plot such as that shown in Fig. 4.

## Acknowledgement

This paper is published by permission of the Building Research Establishment, holder of crown copyright.

## References

1. W. FLUGGE, "Viscoelasticity", (Blaidell Publishing Co., Waltham Mass., 1967).
2. F. KOLLMAN, *Holz als Roh-und Werkstoff*. 19 (3) (1961) 73.
3. R. E. PENTONEY, in "The mechanical behaviour of wood", edited by A. P. Schniewind, (University of California, Berkeley 1963) p. 96-104.
4. A. YLINEN, *Holz als Roh-und Werkstoff*. 5 (1965) 193.
5. T. SZABO and G. IFJU, *Wood Sci.* 2 (3) (1970) 159.
6. J. F. SENFT and S. K. SUDDARTH, *Wood and Fiber* 2 (1971) 321.
7. R. GANOWICZ and K. KWIATKOWSKI, *Holztechnologie*. 15 (2) (1974) 95.
8. N. R. DRAPER and H. SMITH, "Applied regression analysis" (Wiley, New York, 1966).

Received 14 February and accepted 24 February 1977.